

# Engineering Drawing and Design

## ME 1110 - Engineering Practice 1

---

## Lecture 22

# Design Communication

## Oral Presentation

Prof Ahmed Kovacevic

School of Engineering and Mathematical Sciences  
Room CG07, Phone: 8780, E-Mail: [Design@city.ac.uk](mailto:Design@city.ac.uk)

[www.city-design.tk](http://www.city-design.tk)

[www.staff.city.ac.uk/~ra600/intro.htm](http://www.staff.city.ac.uk/~ra600/intro.htm)

# IMPORTANT

---

- 2<sup>nd</sup> progress TEST:
  - » Monday 14<sup>th</sup> April 14,00 – Oakdene
- Testing of paper structures (DP-2):
  - » Groups A&B Thursday 17<sup>th</sup> April 10,00-12,00
  - » Groups C&D Friday 18<sup>th</sup> April 9,00-11,00

# Plan for today

---

- Design PRESENTATION
- REVISE – 2<sup>nd</sup> Progress Test from the previous year

# Engineering Design Process

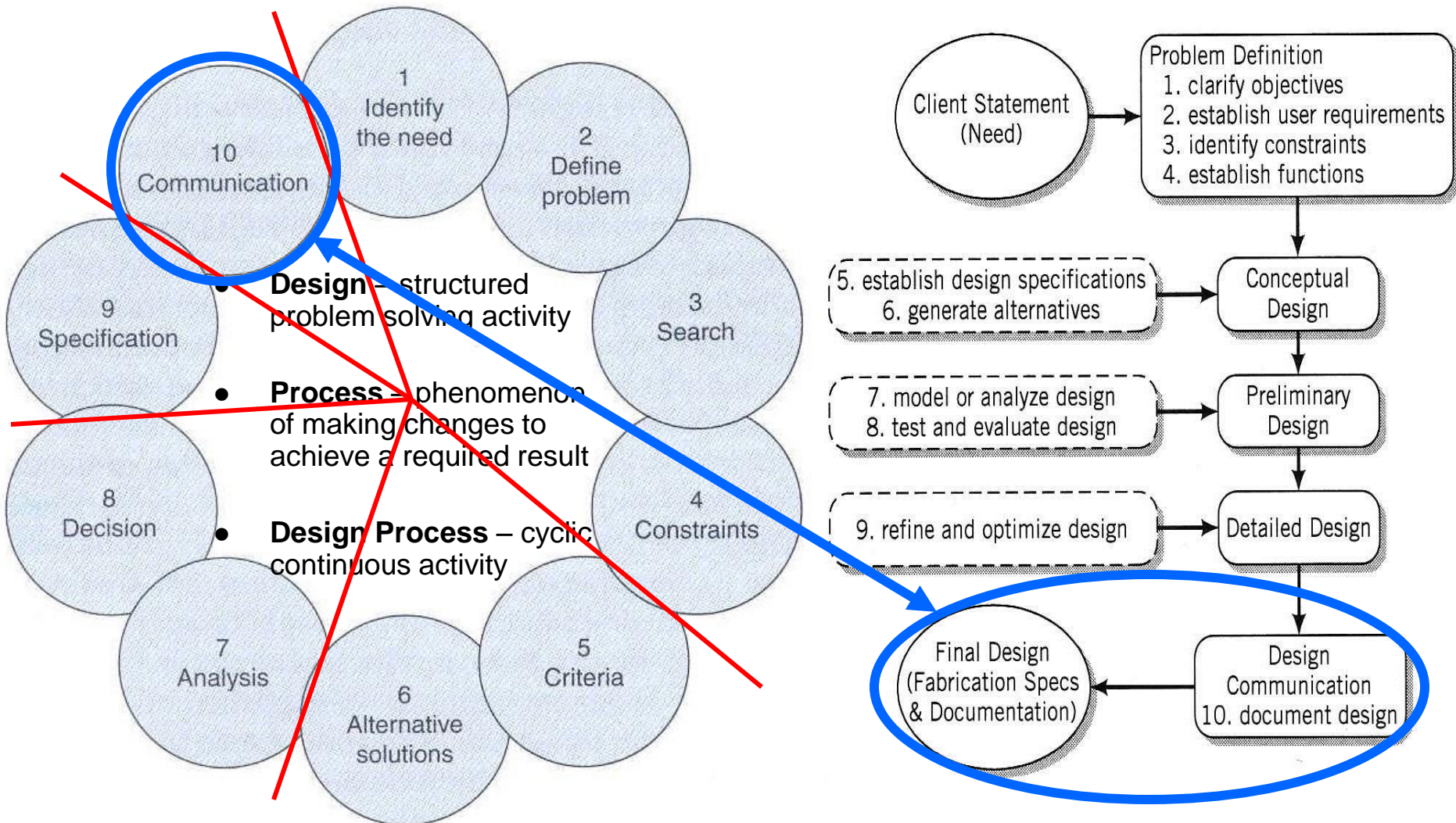

# Introduction

---

- Delivering your presentations effectively involves using a proven four-step process:  
**P**lan, **P**repare, **P**ractice, and **P**resent.
- Follow these guidelines and you and your message will have high impact on your audiences.

# Plan

- Organize Your Presentation

- » Follow a logical progression.
- » Strive to lead your audience to ask a question that is answered on your next slide.
- » Divide your presentation into clear segments.
- » Maintain focus throughout.
- » Narrow the amount of material covered.
- » Have a logical conclusion.

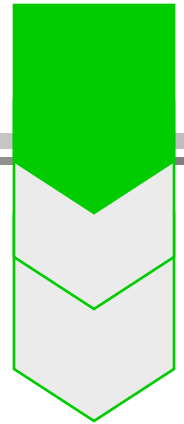

# Plan

---

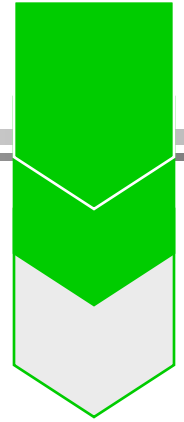

- Describe your audience
  - » Knowledge
  - » Experience
  - » Needs
  - » Goals

# Plan

- Define the purpose of your talk based on the outcome you seek with your audience:
  - » Inform
  - » Persuade
  - » Motivate to action
  - » Sell
  - » Teach
  - » Train

**TIP**

Identify and organize your  
key points



# Prepare

- Maximize Your Effectiveness
  - » Show concern for your audience.
  - » Maintain the relevance of data and information at all times.
  - » The visuals should support and supplement your presentation. They should not dominate.

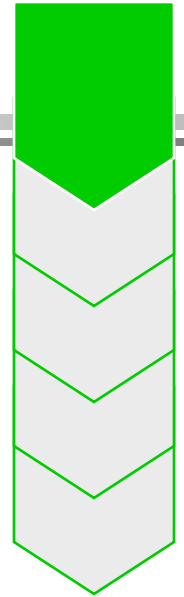

# Prepare

---

- Opening
  - » Establish relevance of topic to audience.
  - » Get audience involvement.

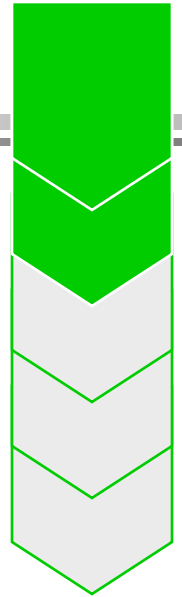

# Prepare

---

- Point #1
  - » Use clear language to state point.
  - » Use evidence both verbal and visual to support your point.
  - » Develop a logical transition or bridge to your next point.

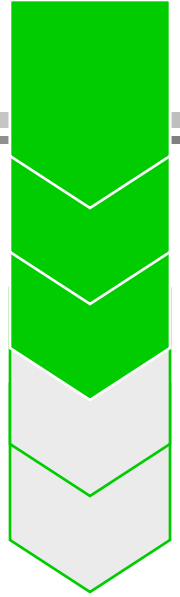

# Prepare

- *Point #2 and Point #3*
  - » Repeat the three-step process under Point #1.

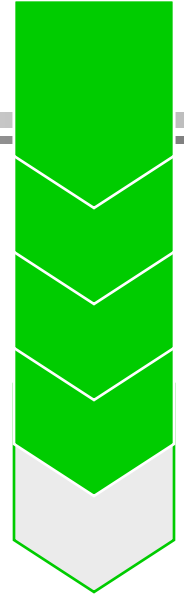

## TIP

As appropriate, supplement your presentation with technical support data in hard copy or on disc, e-mail, internet

# Prepare

- Close

- » Summarize your points.
- » State your conclusion.  
Make it relevant to your audience.

*And, if applicable:*

- » Describe options for future consideration.
- » Recommend a future strategy, plan and/or goal.

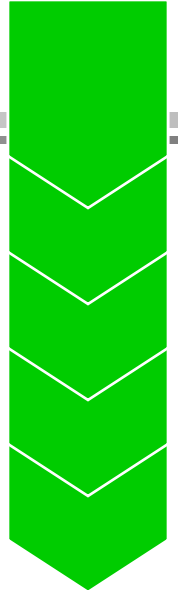

# Practice

---

- Practice your presentation and review your visuals for
  - » Clarity
  - » Relevancy
  - » Eye-appeal
  - » Visibility
  - » Quality
  - » Memorability

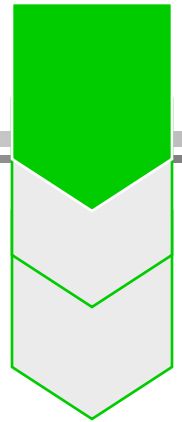

# Practice

- Practice your presentation before an audience, coach, video camera. Receive feedback and coaching on
  - » Strong opening.
  - » Clear key points.
  - » Logical flow.
  - » Credible evidence.
  - and...

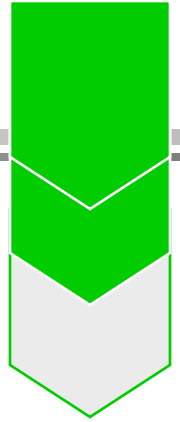

# Practice

---

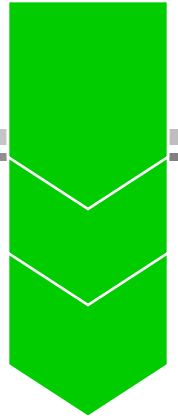

- Also receive feedback and coaching on
  - » Memorable close.
  - » Clarity of message.
  - » Identifying distracting mannerisms.
  - » Results achieved.



# Present

---

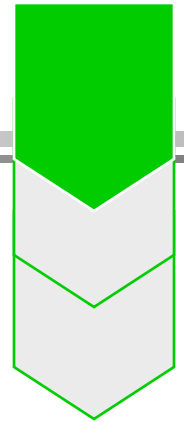

- Make a positive first impression:
  - » Establish eye-contact.
  - » Display poised, confident body language.
  - » Be relaxed.
  - » Be well groomed.

# Present

- Hold the attention of the audience:
  - » Be enthusiastic.
  - » Use vivid words.
  - » Express yourself clearly and concisely.
  - » Tell a story.
  - » Have an upbeat voice.
  - » Have proper body animation.

## TIP

Close your presentation to make a favorable, lasting impression

# Present

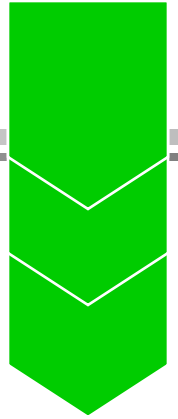

- Strive for continuous improvement:
  - » Measure the success of your talk.
  - » Identify the strengths as well as areas to improve.
  - » Decide how you will improve the next talk.

TIP

Remember to PLAN /  
PREPARE / PRACTICE /  
PRESENT

# Let us REVISE

## Question 1

Indicate whether the following statements are True or False by ticking the appropriate selection box.

T	F	
	X	Engineering design process is an individual task performed to meet some requirement of humankind.
X		Mechanical design process is the use of scientific principles and technical information to define machine that will optimally perform a required function.
	X	General-purpose elements are components of the same machine which are different in the shape and geometry and carry out different tasks.
	X	The isolated system together with all forces and moments due to any external effects and the reactions with the main system is called equilibrium.
X		Strength is an inherent property of a material built into the part because of the use of a particular material and process.
	X	Stress is a state property of a body which is not a function of load, geometry, temperature and manufacturing processing.
	X	A static load is a force or moment with frequent change in magnitude, point of application and direction that acts on a member of a machine or mechanism
X		A static load can be axial tension, compression, a shear load, a bending load, a torsional load or any combination of these.
	X	If the time of application of load is shorter than three times its natural period, dynamic effects are neglected and the load can be considered static.
X		Factor of safety is ratio between loss of a function load and allowable load. strength and stress of a material.

X		Factor of safety is ratio between strength and stress of a material.
X		Thread pitch is a distance between adjacent thread forms measured parallel to the thread axis.
	X	Metric threads are usually pipe threads.
X		Both metric and unified threads can have coarse and fine pitch.
	X	A component that prevents relative motion between two bodies is called bearing.
	X	Ball bearings take more load then cylindrical bearings.
X		Rating life of a bearing, $L_{10}$ is number of revolution or hours of operation that 90% of a group of identical bearings will achieve or exceed before the failure.
	X	An axle is a rotating element that carries torque and is supported by rotating bearings.
	X	The reason to use gears in speed reducers is because torque is easy to generate, while speed is not.
X		The fundamental premise of gearing is to maintain a constant relative rotation rate of gears.
X		Trusses are structures composed entirely of members that are loaded with forces in two points
X		The method of joints employs the summation of forces at a joint to calculate forces in members.
	X	A failure mode is any event that prevents a functional failure of a machine or a system.
X		Failure effects describe what happens when a failure mode occurs

## Question 2

There are eleven (11) general considerations which should be taken into account during a mechanical design of a component or system. These are related to its most important design and manufacturing features. List at least five (5) of these and give their brief explanations.

## Answer

### 1. Type of load and stresses induced;

To design a machine part it is necessary to know the forces, which the part must sustain.

### 2. Motion of the parts or kinematics of the machine;

Forces and their relations change during the motion of the part. The motion of the part may be:

- Rectilinear motion
- Curvilinear motion
- Constant or variable velocity
- Constant or variable acceleration

### 3. Selection of materials;

Body of the component is the material. The designer should have thorough knowledge of the properties of the materials and their behaviour under working conditions.

Important characteristics of materials are: *strength, stiffness/flexibility, durability, weight, resistance to heat, corrosion and wear, ability to cast, weld or hardened, machinability, electrical or magnetic properties etc.*

### 4. Form and size of the parts;

The smallest practicable cross section may be used;

Ensure that the stresses induced are reasonably safe.

Easy to machine. Part or assembly should not involve undue stress concentrations.

Small weight and minimum dimensions should be the criteria (*shape and material*)

### 5. Production soundness;

The component should be designed such that its production requires the minimum expenditure of labour and time.

**6. Number to be manufactured;**

The number of components to be manufactured affects the design in a number of ways.

**7. Cost of construction;**

The cost of construction of a part is one of the most important considerations involved in design. The aim is to reduce the manufacturing costs in any circumstance.

**8. Safety;**

The shape and dimensions of the part should ensure safety of the personnel responsible for not only its manufacture but during its operation in a machine also.

**9. Workshop facilities;**

A design engineer should be familiar with the limitations of the available workshop. Here, the policy to manufacture or to buy should be decided.

**10. Use of standard parts;**

The use of standard parts is closely related to cost.

*The standard or stock parts should be used whenever possible:*

*gears, pulleys, bearings and screws, bolts, nuts, pins.*

Variety (number and size) of such parts should be as few as possible.

**11. Conformance to standards and codes;**

Any part should conform to the standards covering the shape, grade and type of material and safety codes where applicable.

### Question 3

The design of the assembly in Figure a 'Transition fit', class H7 - k6, between the shaft and the crank housing. The transition fit ensures accurate location and stability under varying loads. Some form of mechanical assistance may be required to fit the crank to the shaft.

Using the BS4500A data sheet provided on the next page complete the table given below determining the max. and min. working limits for the diameter of the hole (bush) and shaft end diameter using:

- Class of fit: H7 - k6
- Basic size of 35 mm
- Basic size of 85 mm
- Basic size of your own choice

Also, fill in fields for a maximum and minimum clearance



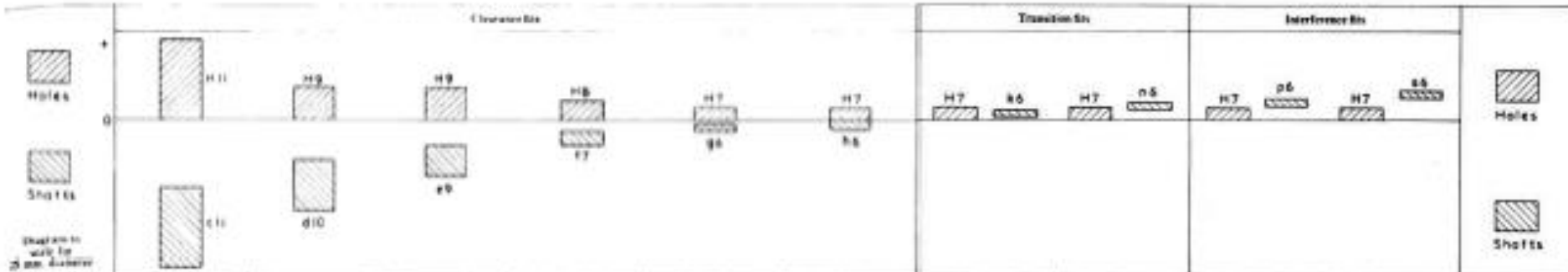

Nominal size	Tolerance	Tolerance		Tolerance		Tolerance		Tolerance		Tolerance		Tolerance		Tolerance		Tolerance		Tolerance		Tolerance		Nominal size	Nominal size
		H11	d11	H9	d10	H8	d9	H7	d8	H7	h6	H7	h5	H7	h6	H7	p6	H7	s5	Over	To		
mm	mm	+0.011 mm	-0.011 mm	+0.009 mm	-0.009 mm	+0.008 mm	-0.008 mm	+0.007 mm	-0.007 mm	+0.006 mm	-0.006 mm	+0.005 mm	-0.005 mm	+0.004 mm	-0.004 mm	+0.003 mm	-0.003 mm	+0.002 mm	-0.002 mm	+0.001 mm	-0.001 mm	mm	mm
—	3	+0.02	-0.02	+0.01	-0.01	+0.01	-0.01	+0.01	-0.01	+0.01	-0.01	+0.01	-0.01	+0.01	-0.01	+0.01	-0.01	+0.01	-0.01	+0.01	-0.01	—	3
3	6	+0.01	-0.01	+0.008	-0.008	+0.007	-0.007	+0.006	-0.006	+0.005	-0.005	+0.004	-0.004	+0.003	-0.003	+0.002	-0.002	+0.001	-0.001	+0.001	-0.001	3	6
6	10	+0.01	-0.01	+0.008	-0.008	+0.007	-0.007	+0.006	-0.006	+0.005	-0.005	+0.004	-0.004	+0.003	-0.003	+0.002	-0.002	+0.001	-0.001	+0.001	-0.001	6	10
10	18	+0.01	-0.01	+0.008	-0.008	+0.007	-0.007	+0.006	-0.006	+0.005	-0.005	+0.004	-0.004	+0.003	-0.003	+0.002	-0.002	+0.001	-0.001	+0.001	-0.001	10	18
18	30	+0.01	-0.01	+0.008	-0.008	+0.007	-0.007	+0.006	-0.006	+0.005	-0.005	+0.004	-0.004	+0.003	-0.003	+0.002	-0.002	+0.001	-0.001	+0.001	-0.001	18	30
30	40	+0.01	-0.01	+0.008	-0.008	+0.007	-0.007	+0.006	-0.006	+0.005	-0.005	+0.004	-0.004	+0.003	-0.003	+0.002	-0.002	+0.001	-0.001	+0.001	-0.001	30	40
40	50	+0.01	-0.01	+0.008	-0.008	+0.007	-0.007	+0.006	-0.006	+0.005	-0.005	+0.004	-0.004	+0.003	-0.003	+0.002	-0.002	+0.001	-0.001	+0.001	-0.001	40	50
50	65	+0.01	-0.01	+0.008	-0.008	+0.007	-0.007	+0.006	-0.006	+0.005	-0.005	+0.004	-0.004	+0.003	-0.003	+0.002	-0.002	+0.001	-0.001	+0.001	-0.001	50	65
65	80	+0.01	-0.01	+0.008	-0.008	+0.007	-0.007	+0.006	-0.006	+0.005	-0.005	+0.004	-0.004	+0.003	-0.003	+0.002	-0.002	+0.001	-0.001	+0.001	-0.001	65	80
80	100	+0.01	-0.01	+0.008	-0.008	+0.007	-0.007	+0.006	-0.006	+0.005	-0.005	+0.004	-0.004	+0.003	-0.003	+0.002	-0.002	+0.001	-0.001	+0.001	-0.001	80	100
100	120	+0.01	-0.01	+0.008	-0.008	+0.007	-0.007	+0.006	-0.006	+0.005	-0.005	+0.004	-0.004	+0.003	-0.003	+0.002	-0.002	+0.001	-0.001	+0.001	-0.001	100	120
120	140	+0.01	-0.01	+0.008	-0.008	+0.007	-0.007	+0.006	-0.006	+0.005	-0.005	+0.004	-0.004	+0.003	-0.003	+0.002	-0.002	+0.001	-0.001	+0.001	-0.001	120	140
140	160	+0.01	-0.01	+0.008	-0.008	+0.007	-0.007	+0.006	-0.006	+0.005	-0.005	+0.004	-0.004	+0.003	-0.003	+0.002	-0.002	+0.001	-0.001	+0.001	-0.001	140	160
160	180	+0.01	-0.01	+0.008	-0.008	+0.007	-0.007	+0.006	-0.006	+0.005	-0.005	+0.004	-0.004	+0.003	-0.003	+0.002	-0.002	+0.001	-0.001	+0.001	-0.001	160	180
180	200	+0.01	-0.01	+0.008	-0.008	+0.007	-0.007	+0.006	-0.006	+0.005	-0.005	+0.004	-0.004	+0.003	-0.003	+0.002	-0.002	+0.001	-0.001	+0.001	-0.001	180	200
200	225	+0.01	-0.01	+0.008	-0.008	+0.007	-0.007	+0.006	-0.006	+0.005	-0.005	+0.004	-0.004	+0.003	-0.003	+0.002	-0.002	+0.001	-0.001	+0.001	-0.001	200	225
225	250	+0.01	-0.01	+0.008	-0.008	+0.007	-0.007	+0.006	-0.006	+0.005	-0.005	+0.004	-0.004	+0.003	-0.003	+0.002	-0.002	+0.001	-0.001	+0.001	-0.001	225	250
250	280	+0.01	-0.01	+0.008	-0.008	+0.007	-0.007	+0.006	-0.006	+0.005	-0.005	+0.004	-0.004	+0.003	-0.003	+0.002	-0.002	+0.001	-0.001	+0.001	-0.001	250	280
280	315	+0.01	-0.01	+0.008	-0.008	+0.007	-0.007	+0.006	-0.006	+0.005	-0.005	+0.004	-0.004	+0.003	-0.003	+0.002	-0.002	+0.001	-0.001	+0.001	-0.001	280	315
315	355	+0.01	-0.01	+0.008	-0.008	+0.007	-0.007	+0.006	-0.006	+0.005	-0.005	+0.004	-0.004	+0.003	-0.003	+0.002	-0.002	+0.001	-0.001	+0.001	-0.001	315	355
355	400	+0.01	-0.01	+0.008	-0.008	+0.007	-0.007	+0.006	-0.006	+0.005	-0.005	+0.004	-0.004	+0.003	-0.003	+0.002	-0.002	+0.001	-0.001	+0.001	-0.001	355	400
400	450	+0.01	-0.01	+0.008	-0.008	+0.007	-0.007	+0.006	-0.006	+0.005	-0.005	+0.004	-0.004	+0.003	-0.003	+0.002	-0.002	+0.001	-0.001	+0.001	-0.001	400	450
450	500	+0.01	-0.01	+0.008	-0.008	+0.007	-0.007	+0.006	-0.006	+0.005	-0.005	+0.004	-0.004	+0.003	-0.003	+0.002	-0.002	+0.001	-0.001	+0.001	-0.001	450	500

Stack fit, Loose fit, Easy fit, Normal fit, Close fit, Slide fit, Push fit, Drive fit, Press fit, Force fit

Tolerance		Nominal sizes	
H7	h6	Over	To
0-001 mm	0-001 mm	mm	mm
+18 0	+6 +8	—	3
+12 0	+4 +1	3	6
+15 0	+10 +1	6	10
+18 0	+12 +1	10	18
+21 0	+15 +2	18	30
+25 0	+18 +2	30	40
		40	50
+30 0	+21 +2	50	65
		65	80
+33 0	+25 +1	80	100
		100	120

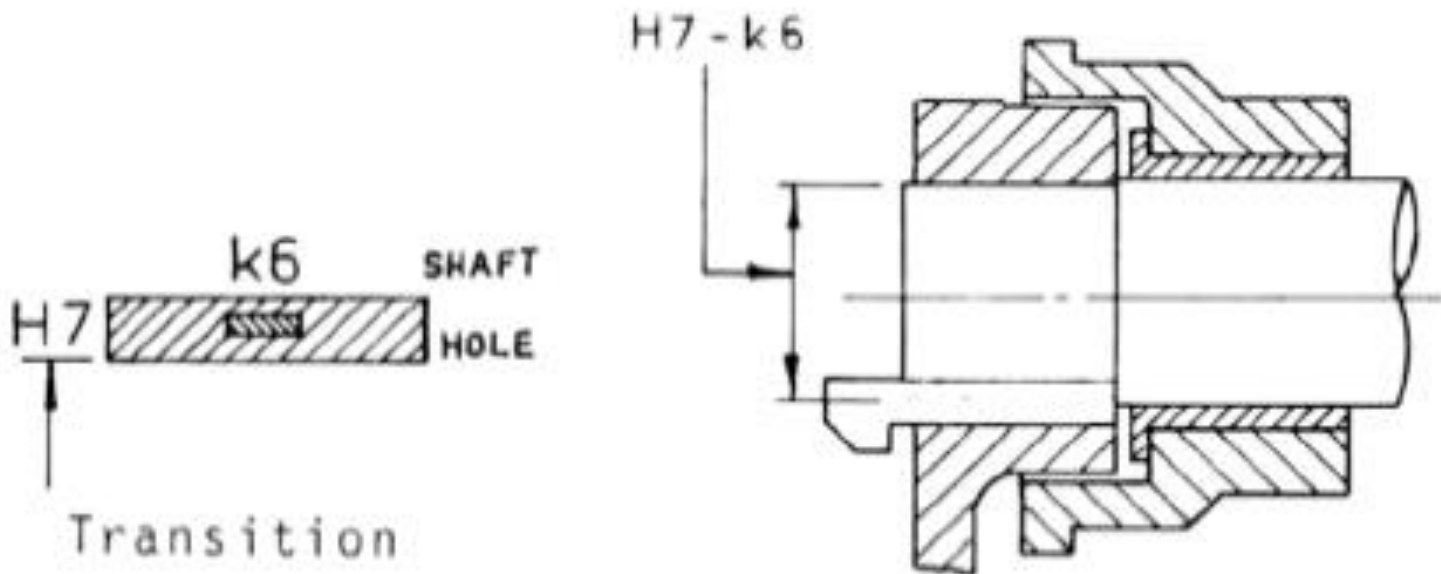

Hole					Shaft					Clearance	
Basic size	Upper tol.	Lower tol.	Max. size	Min. size	Basic size	Upper tol.	Lower tol.	Max. size	Min. size	Min	Max
$\phi$ 35	+0.025	0	35.025	35.0	$\phi$ 35	+0.018	+0.002	35.018	35.002	-0.018	+0.023
$\phi$ 85	+0.035	0	85.035	85.0	$\phi$ 85	+0.025	+0.003	85.025	85.003	-0.025	+0.032
$\phi$					$\phi$						