

The Design of a Family of Screw Compressors for Oil-Flooded Operation

K Venu Madhav

Elgi Equipments, Coimbatore, India

N Stosic, I K Smith and A Kovacevic

Centre for positive displacement compressor technology
City University, London, EC1V 0HB, U.K.

ABSTRACT

The design of a family of efficient oil-flooded twin screw air compressors was performed at City University London for Elgi Equipments Coimbatore, India. It was carried out using a software package, which included almost every aspect of the rotor profiling and compressor thermodynamic and geometric modelling with the capacity to transmit calculated output directly into a CAD drawing system. Rack generated 'N' rotors of the 4/5 configuration were applied to 5 screw compressors which covered deliveries between 0.6 to 60 m³/min.

The compressor family is being gradually introduced by manufacturing prototypes, pre-production compressors and finally, production units. Experimental tests showed that at delivery pressures between 5 and 13 bar gauge the compressor volumetric and adiabatic efficiencies were high when compared with the best compressors currently manufactured.

1 INTRODUCTION

There are relatively few publications on screw compressor design since their large scale manufacture began in the early nineteen seventies as a result of the introduction of the 'A' profile by the Swedish company, SRM. However, the principles on which this was based, were published earlier by *Sakun 1960* [1]. *Amosov et al 1977* [2] later reviewed contemporary profiles in their handbook on screw compressors, in Russian and *Rinder 1979* [3] gives a comprehensive description of the 'A' profile in his book in German. Later, *O'Neill 1993* [4] produced a book on industrial compressors with a major part devoted to screw compressors while *Arbon 1994* [5] dedicated his book exclusively to twin shaft compressors. Only recently *Xing, 2000* [6] published a comprehensive book on this topic but it is written in Chinese.

The majority of screw compressors are still manufactured with 4 lobes in the main rotor and 6 lobes in the gate rotor with both rotors of the same outer diameter. This configuration is a compromise which has favourable features for both, dry and oil-flooded compressor application and is used for air and refrigeration or process gas compressors. However, other

configurations, like 5/6 and 5/7 and recently 4/5 and 3/5 are becoming increasingly popular. Five lobes in the main rotor are suitable for higher compressor pressure ratios, especially if combined with larger helix angles. The 4/5 arrangement has emerged as the best combination for oil-flooded applications of moderate pressure ratios. The 3/5 is favoured in dry applications, because it offers a high gear ratio between the gate and main rotors which may be taken advantage of to reduce the required drive shaft speed.

In the U.K, Compair pioneered the use of the 4/5 combination with their 'Cyclon' rotors. They were soon followed by Tamrotor in Finland, who produced a very efficient family of oil-flooded screw air compressor called 'Enduro' using SRM 'D' rotors. The 4/5 configuration permits the smallest overall dimension for the rotors compared to any other reasonable combination. Also, one less lobe in the gate rotor compared with the 4/6 combination can improve the efficiency of the rotor manufacturing.

2 ESTIMATION OF THE COMPRESSOR FAMILY SIZE AND ITS PERFORMANCE

The specification for the compressor family was for an air delivery of 0.6–60 m³/min at 5–13 bars gauge with a maximum pressure of 15 bars.

Based on the success of an earlier design, the 4/5 rotor configuration with 'N' profiles developed at City University, London, was selected for the entire family of units required to cover this range. The rotor profiles were generated using the rack principle, as described by *Stosic and Hanjalic, 1997* [7].

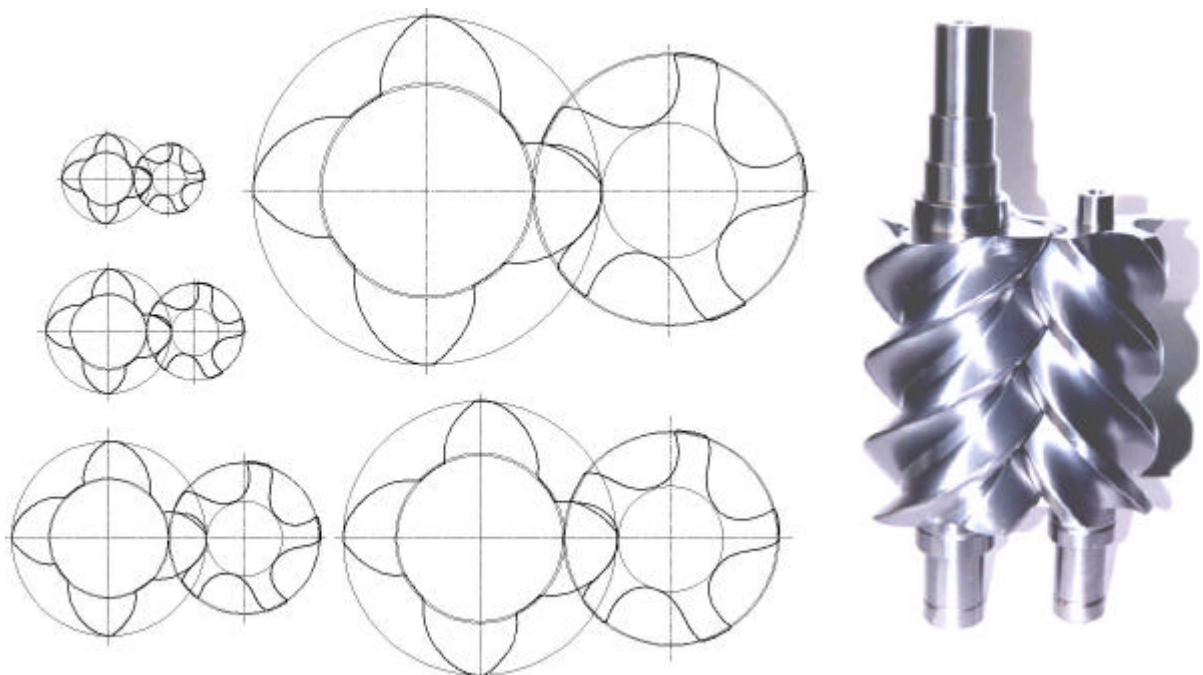

Fig 1. 4/5 'N' rotors scaled for the family of screw air compressors

This profile/configuration combination has the advantage of high displacement with a short sealing line together with a small blow-hole area, when optimised for medium pressure air compression. A low torque to the gate rotor and involute rotor contact resulted in low rotor surface stress, while 'negative' torque on the gate rotor causes contact along the straight flanks, which minimises the interlobe leakage path.

A software package for design of screw compressors developed by the authors, described in *Hanjalic and Stosic, 1997* [8], was used to determine the optimum rotor size and speed and the compressor volume ratio. The output from this, which included almost every aspect of geometric and thermodynamic modelling and capacity was transmitted directly into a CAD drawing system. The entire flow range required was thereby covered by only 5 rotor sizes, all of the same L/D ratio of 1.55, thus unifying the rotor profiles and compressor shapes and forms for the whole family. The main rotor diameters thus selected were 73, 102, 159, 225 and 284 mm diameter and these are shown in Fig. 1 together with a photograph of one of them.

As can be seen in Fig 1, 'N' rotors have very strong gate profile lobes. This allows higher cutting forces to be applied during their manufacturing by the milling manufacturing procedure. The milling tool to produce them was also designed at City University.

The main performance parameters calculated by the simulation program, are presented in logarithmic coordinates in Fig. 2.

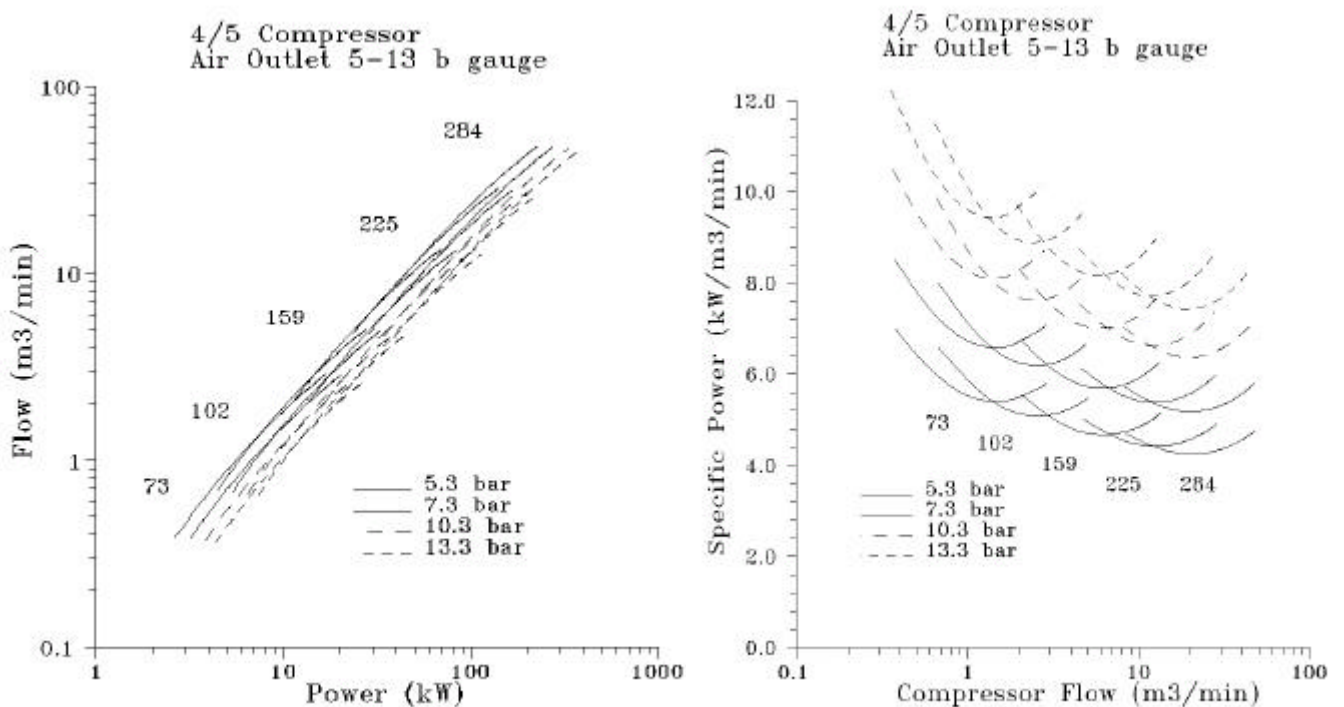

Fig 2 Predicted Performance of the Elgi family of oil-flooded air compressors

3 MECHANICAL DESIGN OF THE COMPRESSOR FAMILY

On completion of the rotor profile generation and thermodynamic performance estimation by the design software, the component sizes and shapes, as well as the resulting force loads thus estimated, were transferred to a CAD system by means of a full internal interface. In addition, modern design concepts, such as late closing of the suction port and early exposure of the discharge port were included, together with improved bearing and seal specification, to maximise the compressor endurance and reliability, as presented by *Stosic et al, 1997* [9].

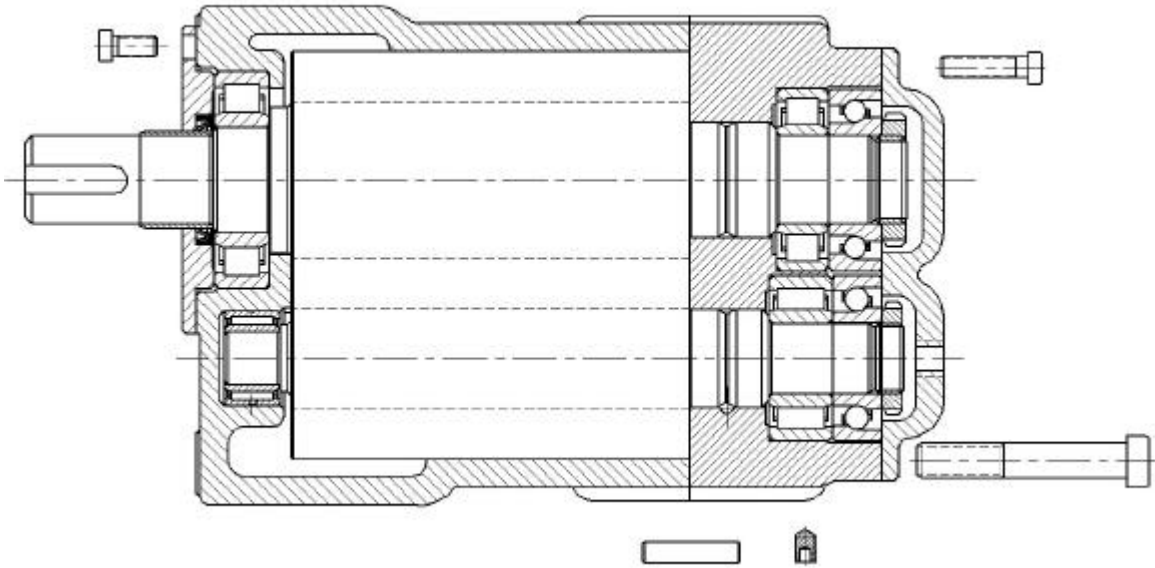

Fig. 3 The smallest compressor of the family, 4/5-73 mm

The key factor for all screw compressor applications is the rotor design. Although advanced rotor profiles are a necessary condition for a screw compressor to be efficient, all other components must be designed to enhance rotor superiority if their full advantage is to be achieved. Thus rotor to housing clearances, especially at the high pressure end must be properly selected. This in turn requires either expensive bearings with smaller clearances or cheaper bearings with their clearances reduced to an acceptable value by preloading. The latter practice was chosen as the most convenient and economic solution.

A screw compressor, especially of the oil flooded type, which operates with high pressure differences, is heavily loaded by axial and radial forces which are transferred to the housing by the bearings. Rolling element bearings are normally chosen for small and medium screw compressors and these must be carefully selected to obtain a satisfactory design. Usually two bearings are employed on the discharge end of the rotor shafts in order to absorb the radial and axial loads separately. Also the distance between the rotor centre lines is in part determined by the bearing size and internal clearance. An assembly drawing of the compressor is shown in Fig 3 in which the bearing arrangement can be seen.

The same oil is used for rotor flooding and for bearing lubrication but the supply to and evacuation from the bearings is separate to minimise the bearing friction losses. Oil is injected into the compressor chamber at the place where thermodynamic calculations show the air and oil inlet temperature to coincide. The position is defined on the rotor helicoid with the injection hole located so that the oil enters tangentially in line with the gate rotor tip in order to recover as much as possible of the oil kinetic energy.

Special care was given to minimise the flow losses in the suction and discharge ports. The suction port is positioned in the housing to let the air enter with the fewest possible bends and the air approach velocity is kept low by making the flow area as large as possible. The photograph in Fig 3 demonstrates this feature. The discharge port size was first determined by estimating the built-in-volume ratio required for optimum thermodynamic performance. It was then increased in order to reduce the exit air velocity and hence obtain the minimum combination of internal and discharge flow losses.

The cast iron casing, which was carefully dimensioned to minimize its weight, contained a reinforcing bar visible in Fig. 3 across the suction port to improve its rigidity at higher pressures. After casting it was hydraulically tested at a pressure of 22.5 bar.

The mechanical design of the compressor family was performed interactively and involved close liaison between the authors at the Centre and Elgi engineers. The first two compressors were designed fully by the Centre, while the third and fourth compressors were designed by the manufacturer's designer under direct supervision of the Centre. Finally, the fifth compressor was designed by the manufacturer's engineers. All other activities, including tool and rotor manufacture and compressor production and assembly were performed at the manufacturer's premises in India.

4 TESTING OF THE COMPRESSOR PROTOTYPES

Two test rigs were used for simultaneous testing of the compressor prototypes, one at City University and another at Elgi. Both test rigs meet all Pneurop/Cagi requirements for screw compressor acceptance tests. The compressors were tested according to ISO 1706 and their delivery flow was measured following BS 5600. High accuracy test equipment was used for the measurement of all relevant parameters.

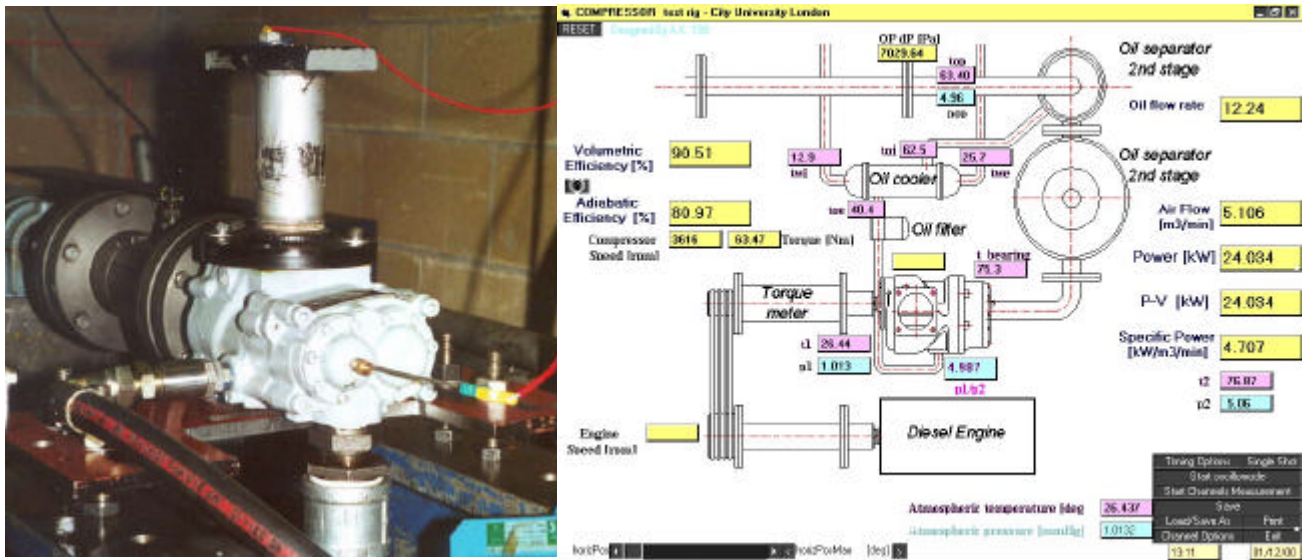

Fig. 4 Compressor test layout and the computer screen

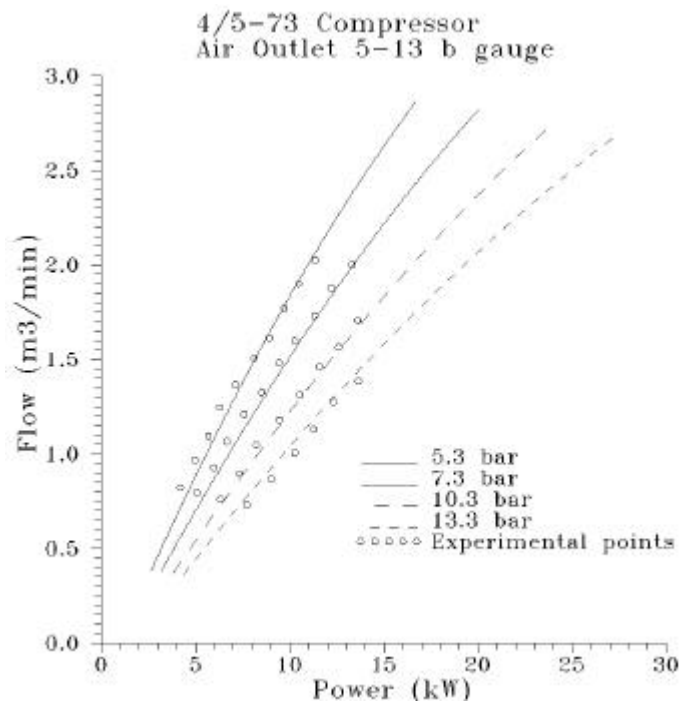

Fig. 5 Comparison of the estimated and measured flow in function of compressor power, Compressor 4/5-73

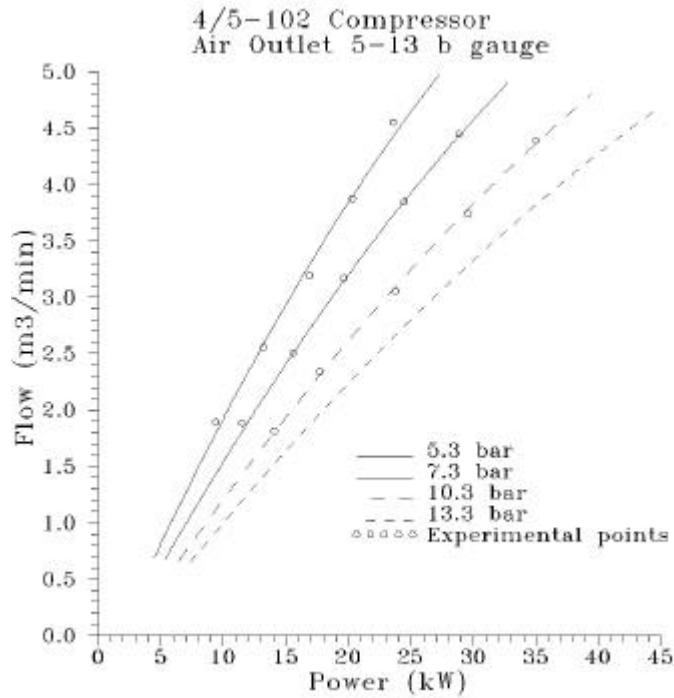

Fig. 6 Comparison of the estimated and measured flow in function of compressor power, Compressor 4/5-102

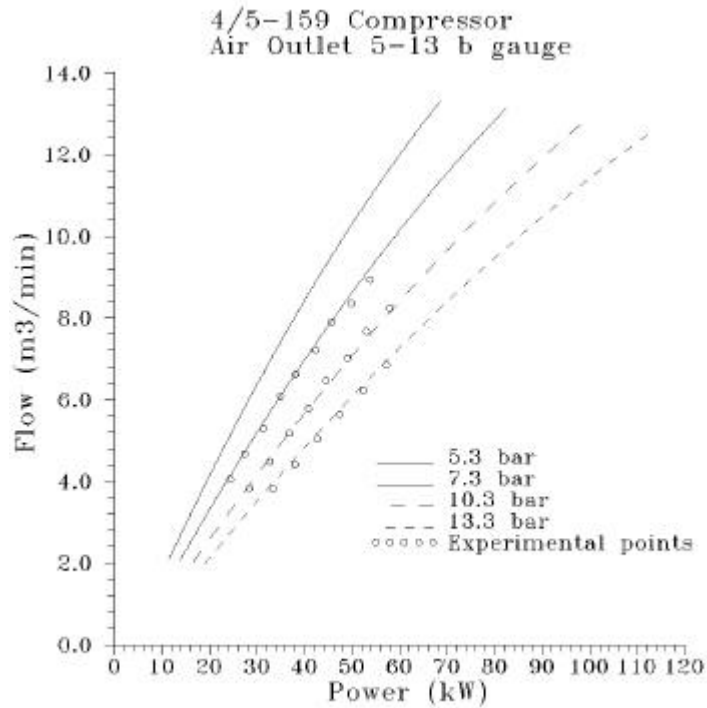

Fig. 5 Comparison of the estimated and measured flow in function of compressor power, Compressor 4/5-159

The measurements were taken by transducers and both recorded and processed in a computerized data logger for real time presentation. A screen record of the compressor measurement is given in Fig. 4. A Diesel engine prime mover of 100 kW maximum output, which may operate at variable speed, was used as a prime mover. This enabled the testing of oil-flooded screw compressors with discharge rates of up to 16 m³ /min.

At the time of writing of this paper, three compressor sizes had been produced and tested. Measured values were used to calculate compressor flow, power and specific power and the oil injection rate was estimated by means of a heat balance. Both the predicted and measured test results of three compressor sizes, namely the 4/5-73 mm, 4/5-102 and 4/5-159 mm units are presented in Figs 5, 6 and 7 in the form of compressor flow as a function of input power. As may be observed, the correlation between the estimated and measured values is good and it may be concluded from the plot of specific power, given in Fig 2 that the compressor efficiency is higher than in majority of commercially available compressors.

The experimentally derived compressor performance data has been compared with results taken from brochures issued by all well known manufactures of equivalent machines. It should be noted that there are wide variations between machines and it is normal practice to base such publications on the best results. Despite this, no published results could be found with better performance than that recorded in this paper.

5 CONCLUSION

The execution of the development of the compressor family described in this paper has been used as an opportunity to publicise the advantages of advanced simulation models and modern rotor profiling techniques to determine the optimum rotor profile, size and speed, the volume ratio and the shape and position of the suction and discharge and oil port. These have been made easy to incorporate into the design by the ability to transfer the output data thus derived directly in a CAD system. However, it should be noted that, apart from the improvements made due to the superior rotor profile and computer optimisation, attention was paid to every detail of the designs such as the ports, the oil injection system and the bearings in order to derive the full benefit possible from this approach. The high efficiencies obtained on test, as well as the reduced size and weight of these machines, compared to the models which they have been designed to replace, all confirm the validity of this approach.

REFERENCES

- 1 Sakun I.A, 1960: Vintovie kompresorii, (screw Compressors) Mashinostroenie Leningrad
- 2 Amosov P.E, Bobrikov, N.I, Schwartz A.I, Vernii A.L, 1977: Vintovie kompresornie mashinii - Spravochnik, (Handbook of Screw Compressor Machines) Mashinostroenie, Leningrad
- 3 Rinder L, 1979: Schraubenverdichter (Screw Compressors), Springer Verlag, New York
- 4 O'Neill P.A, 1993: Industrial Compressors, Theory and Equipment, Butterworth-Heinemann, Oxford
- 5 Arbon A, 1994: Twin Shaft Compressors in Gas Process Industry, IMechE Publications London
- 6 Xing Z. W, 2000: Screw Compressors, Machine Press, Beijing
- 7 Stosic N, Hanjalic K, 1997: Development and Optimization of Screw Machines with a Simulation Model, Part I: Profile Generation, ASME Transactions, Journal of Fluids Engineering, Vol 119, p 654
- 8 Hanjalic K, Stosic N, 1997: Development and Optimization of Screw Machines with a Simulation Model, Part II: Thermodynamic Performance Simulation and Design Optimization, ASME Transactions, Journal of Fluids Engineering, Vol 119, p 659
- 9 Stosic N, Smith I. K, Kovacevic A, Aldis C. A, 1997: The Design of a Twin-screw Compressor Based on a New Profile, Journal of Engineering Design, Vol 8, 389