

**City University London**  
**Term 2 Assessment, 2003/2004**

**School of Engineering and Mechanical Sciences**

**ME1105 Engineering Drawing & Design**

Student Name ..... , Group: .....

# SOLUTIONS

Max. No of Marks: **30**

**Examination duration:** 1 hour  
**Reading time:** 5 minutes  
**This paper has:** 5 pages

**Authorized materials:**

Electronic calculators and drawing instruments may be used.

**Instructions to invigilators:** Candidates are to complete the examination by writing and drawing **in this examination paper**, which must be collected at the end of the examination. The data required for solutions are attached to this paper. Therefore, no additional script books should be required.

**Instructions to students:**

Attempt **all** of the three questions. All questions are of equal value.  
Space is provided **in this paper** to complete all the questions. No additional script books should be required. The whole paper must be left for collection by the invigilators at the end of the examination.

**DO NOT DETACH PAGES FROM THIS PAPER!**

**REMEMBER: WRITE YOUR NAME AND GROUP in the provided space.!**

### Question 1

Indicate whether the following statements are True or False by **ticking** the appropriate selection box.

T	F	
	X	Engineering design process is an individual task performed to meet some requirement of humankind.
X		Mechanical design process is the use of scientific principles and technical information to define machine that will optimally perform a required function.
	X	General-purpose elements are components of the same machine which are different in the shape and geometry and carry out different tasks.
	X	The isolated system together with all forces and moments due to any external effects and the reactions with the main system is called equilibrium.
X		Strength is an inherent property of a material built into the part because of the use of a particular material and process.
	X	Stress is a state property of a body which is not a function of load, geometry, temperature and manufacturing processing.
	X	A static load is a force or moment with frequent change in magnitude, point of application and direction that acts on a member of a machine or mechanism
X		A static load can be axial tension, compression, a shear load, a bending load, a torsional load or any combination of these.
	X	If the time of application of load is shorter than three times its natural period, dynamic effects are neglected and the load can be considered static.
X		Factor of safety is ratio between loss of a function load and allowable load. strength and stress of a material.
X		Factor of safety is ratio between strength and stress of a material.
X		Thread pitch is a distance between adjacent thread forms measured parallel to the thread axis.
	X	Metric threads are usually pipe threads.
X		Both metric and unified threads can have coarse and fine pitch.
	X	A component that prevents relative motion between two bodies is called bearing.
	X	Ball bearings take more load then cylindrical bearings.
X		Rating life of a bearing, $L_{10}$ is number of revolution or hours of operation that 90% of a group of identical bearings will achieve or exceed before the failure.
	X	An axle is a rotating element that carries torque and is supported by rotating bearings.
	X	The reason to use gears in speed reducers is because torque is easy to generate, while speed is not.
X		The fundamental premise of gearing is to maintain a constant relative rotation rate of gears.
X		Trusses are structures composed entirely of members that are loaded with forces in two points
X		The method of joints employs the summation of forces at a joint to calculate forces in members.
	X	A failure mode is any event that prevents a functional failure of a machine or a system.
X		Failure effects describe what happens when a failure mode occurs.

## Question 2

There are eleven (11) general considerations which should be taken into account during a mechanical design of a component or system. These are related to its most important design and manufacturing features. List at least five (5) of these and give their brief explanations.

### Answer

**1. Type of load and stresses induced;**

To design a machine part it is necessary to know the forces, which the part must sustain.

**2. Motion of the parts or kinematics of the machine;**

Forces and their relations change during the motion of the part. The motion of the part may be:

- Rectilinear motion
- Curvilinear motion
- Constant or variable velocity
- Constant or variable acceleration

**3. Selection of materials;**

Body of the component is the material. The designer should have thorough knowledge of the properties of the materials and their behaviour under working conditions.

Important characteristics of materials are: *strength, stiffness/flexibility, durability, weight, resistance to heat, corrosion and wear, ability to cast, weld or hardened, machinability, electrical or magnetic properties* etc.

**4. Form and size of the parts;**

The smallest practicable cross section may be used;

Ensure that the stresses induced are reasonably safe.

Easy to machine. Part or assembly should not involve undue stress concentrations.

Small weight and minimum dimensions should be the criteria (*shape and material*)

**5. Production soundness;**

The component should be designed such that its production requires the minimum expenditure of labour and time.

**6. Number to be manufactured;**

The number of components to be manufactured affects the design in a number of ways.

**7. Cost of construction;**

The cost of construction of a part is one of the most important considerations involved in design. The aim is to reduce the manufacturing costs in any circumstance.

**8. Safety;**

The shape and dimensions of the part should ensure safety of the personnel responsible for not only its manufacture but during its operation in a machine also.

**9. Workshop facilities;**

A design engineer should be familiar with the limitations of the available workshop. Here, the policy to manufacture or to buy should be decided.

**10. Use of standard parts;**

The use of standard parts is closely related to cost.

*The standard or stock parts* should be used whenever possible:

*gears, pulleys, bearings and screws, bolts, nuts, pins.*

Variety (number and size) of such parts should be as few as possible.

**11. Conformance to standards and codes;**

Any part should conform to the standards covering the shape, grade and type of material and safety codes where applicable.

### Question 3

The design of the assembly in Figure a 'Transition fit', class H7 - k6, between the shaft and the crank housing. The transition fit ensures accurate location and stability under varying loads. Some form of mechanical assistance may be required to fit the crank to the shaft.

Using the BS4500A data sheet provided on the next page complete the table given below determining the max. and min. working limits for the diameter of the hole (bush) and shaft end diameter using:

- Class of fit: **H7 - k6**
- Basic size of **35 mm**
- Basic size of **85 mm**
- Basic size of your own choice

Also, fill in fields for a maximum and minimum clearance

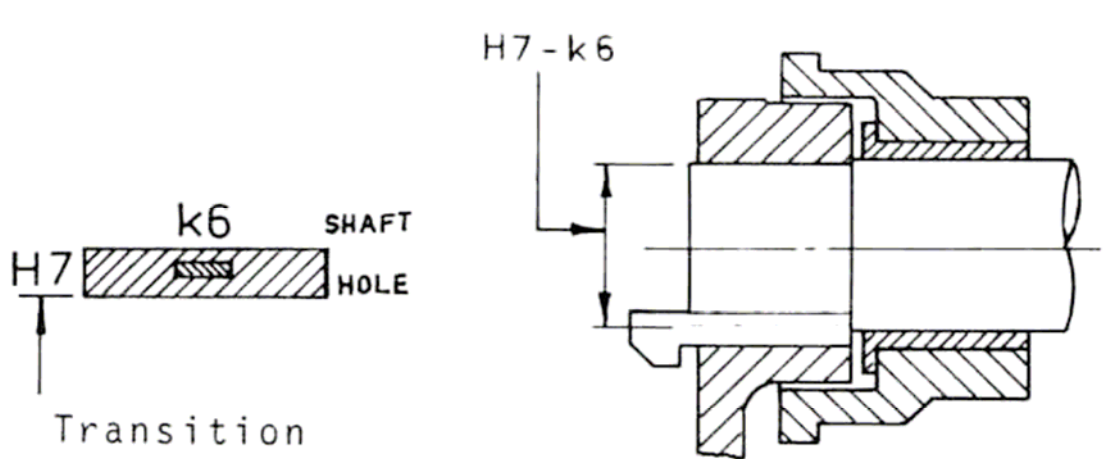

Hole					Shaft					Clearance	
Basic size	Upper tol.	Lower tol.	Max. size	Min. size	Basic size	Upper tol.	Lower tol.	Max. size	Min. size	Min	Max
$\phi$ 35	+0.025	0	35.025	35.0	$\phi$ 35	+0.018	+0.002	35.018	35.002	-.018	+.023
$\phi$ 85	+0.035	0	85.035	85.0	$\phi$ 85	+0.025	+0.003	85.025	85.003	-.025	+.032
$\phi$					$\phi$						

