

COMBINED COMPRESSOR-EXPANDER IN FUEL CELL APPLICATION

Nikola Stosic, Ian K. Smith and Ahmed Kovacevic

City University, London EC1V OHB, U.K.
Tel +44 20 7477 8780, Fax +44 7477 8566
e- Centre for Positive Displacement Compressor Technology,
mail: n.stosic@city.ac.uk

Abstract. *To improve efficiency of fuel cells working on the proton exchange membrane principle, which are currently being developed for automotive applications, a supply of pressurized air at about 3 bars abs is required. This is expelled in the reaction products, mainly as water and nitrogen, at approximately 100°C. The power input required to compress the air consumes approximately 20% of the cell electrical output. To recover a part of the compressor power and to extract water, the reaction products must be expanded. It is shown that a twin screw machine can perform both the compression and expansion functions using only one pair of rotors. Moreover, by proper location of the ports, mechanical friction losses within it will be less than if the two functions are performed in separate machines.*

Key Words. *Fuel Cells, Screw Compressor, Expander, Energy Efficiency, Environmental Sustainability*

1. Introduction

The bulk of world funding dedicated to introduction of fuel cells is being directed to using fuel cells to replace the internal combustion engine in automotive applications. The principle on which hydrogen fuel cells operate was first enunciated by Grove in 1839 and, initially, the thermodynamic process on which they operate, was called ‘inverse electrolysis’ or ‘cold combustion’. Despite the length of time since this operating principle was first recognised, many problems were encountered in trying to introduce fuel cells as an energy source and probably their first successful use up to now was in manned space vehicles, which began only in the second half of the 20th century. In this case, hydrogen and oxygen were already on board the spacecraft and the water by-product was used to satisfy human needs. Hence, neither efficiency nor cost were the most significant concerns for that application. The main directions of contemporary fuel cell development are in reduction of the volume of the fuel cell stacks, humidifiers, air managing and the fuel handling and conditioning systems. The trend appears to be for specialist institutions to develop the individual fuel cell elements and components, rather than single companies attempting to do everything, as was the case until fairly recently.

Fuel cells have a high thermodynamic efficiency at low current densities. However, increased electricity demand is associated with higher electric current, which results in greater resistance losses, and consequently a decrease in the cell voltage and efficiency. Numerous refinements are therefore necessary to minimise these adverse effects. One of the most promising of these is to increase the cell working pressure. A compressor is then required to admit the air supply. If water injection is included in the compression process, the air discharge temperature is almost independent of the discharge pressure. The cell voltage, which is proportional to the logarithm of the square root of the pressure ratio, can thereby be increased. This is a desirable feature for high power output. In addition, the cell size will be reduced, roughly in proportion to the compressor pressure ratio, which is a ratio of the discharge and suction pressure. This is a major consideration for automotive applications. Also, a higher pressure allows higher humidification rates, which has the favourable effect of increasing the working medium electrical conductivity.

It is widely accepted that hydrogen proton exchange membrane fuel cells are the most promising fuel cell choice for the automotive industry and these are now being developed intensively. In the automotive range they require a continuous supply of saturated air at flow rates of 100-300 kg/hr at approximately 3 bar abs. The products of the reaction, containing mainly nitrogen and water, are rejected from them at approximately 80-100°C and 2.8 bar. The power input required to compress the air is approximately 20% of the cell electrical output. Hence, for the cell efficiency to be acceptable, power should be recovered from expansion of the discharged reaction products and used to reduce the electrical power consumed by the compressor.

Although there are many publications on fuel cells, few of them are concerned with their interaction with compressors and these are very recent. *Kauder and Temming, 2002* give a comprehensive paper covering a full review of screw compressors in fuel cell applications which includes all major design and operational aspects of this application. *Hinsenkamp and Romba, 2002* define the compressor and compressor-expander characteristics required for their inclusion

in fuel cell systems to be acceptable. These are somewhat exaggerated and give little incentive to include compressors in fuel cell systems.

If a twin-screw machine is used to expand the reaction products, a very convenient means of fuel cell pressure control can be used. This is to vary the geometry of the expander inlet by the use of a sliding valve or other device, similar to that described by *Fannar, 2001*. This is preferable to the use of a pre discharge blow-off valve, which releases part of the partially pressurised air to the compressor suction, as is normally used in volumetric superchargers.

The air can be humidified by the injection of water, recovered from the expansion process, into the compressor suction or compression chamber. This may be regarded as an additional advantage to the use of screw compressors in fuel cell systems.

Fuel cell membranes are highly sensitive to contaminants. Hence, sophisticated lubrication systems, which prevent oil entering the air stream, are required for the compressor bearings and drive gears and compressors must be manufactured from special materials or coatings. This significantly increases the manufacturing costs.

Additionally, since compressors are usually the noisiest components of the entire fuel cell system, their sound emission must be minimised. This also increases the compressor cost.

As concluded by *Kauder and Temming, 2002*, screw machines, due to their simplicity, effectiveness, reliability, efficiency and undisturbed straightforward fluid flow, represent the best choice both for compression of the air and expansion of the reaction products in fuel cells. They proposed two modes of linking the expander power to the compressor drive, namely:

- i) Independent connection of the compressor to a drive motor and the expander to a generator.
- ii) Coupling of the compressor and expander either by direct connection or via a gearbox.

The first mode is more flexible, but has a relatively low efficiency due to the double electrical transformation required to use the power recovered from the expander to drive the compressor. Although the expander and compressor rotors are coupled in the second mode, they are separate and independently machined and thus may have either similar or different profiles.

An alternative and simpler approach is proposed here. This is to use only one pair of rotors to perform both the compressor and expander functions. This is a concept that has been developed by the authors over many years.

Initially, *Smith and Stosic, 1995*, proposed to link a compressor and expander as a self-driven unit to recover power from the throttling process in vapour compression systems. Subsequently, as reported by *Stosic et al, 2001*, an experimental investigation was carried out on a means of performing the same function in a unit with only one pair of rotors contained in a single chamber with three ports. A more generalised version of this concept, which involved dividing the compression and expansion processes into two separate chambers was proposed in a patent application by *Stosic et al, 2002 a*. An example of its application to replace the main compressor a high pressure refrigeration system is given by *Stosic et al, 2002 b*, who described such an arrangement as 'multifunctional rotors' for simultaneous compression and expansion.

2. Combined Compression and Expansion in One Pair of Screw Rotors

Screw compressors are positive displacement rotary machines, which essentially consist of a pair of meshing helical lobed rotors contained in a casing. Together, these form a series of working chambers, as shown in Fig 1, by means of views from opposite ends and sides of the machine. The dark shaded portions show the enclosed region where the rotors are surrounded by the casing and compression takes place, while the light shaded areas show the regions of the rotors which are exposed to external pressure. The large light shaded area in Fig 1a) corresponds to the low pressure port. The small light region between shaft ends B and D in Fig 1b) corresponds to the high pressure port. Admission of the gas to be compressed occurs through the low pressure port which is formed by opening the casing surrounding the top and front face of the rotors. Exposure of the space between the rotor lobes to the suction port, as their front ends pass across it, allows the gas to fill the passages formed between them and the casing. Further rotation then leads to cut off of the port and progressive reduction in the trapped volume in each passage, until the rear ends of the passages between the rotors are exposed to the high pressure discharge port. The gas then flows out through this at approximately constant pressure.

An important feature of screw machines, which can well be appreciated from examination of Fig 1, is that if the direction of rotation of the rotors is reversed, then gas will flow into the machine through the high pressure port and out through the low pressure port and it will act as an expander. The machine will also work as an expander when rotating in the same direction as a compressor provided that the suction and discharge ports are positioned on the opposite sides of the casing to those shown since this is effectively the same as reversing the direction of rotation relative to the ports. When

operating as a compressor, mechanical power must be supplied to shaft A to rotate the machine. When acting as an expander, it will rotate automatically and power generated within it will be supplied externally through shaft A.

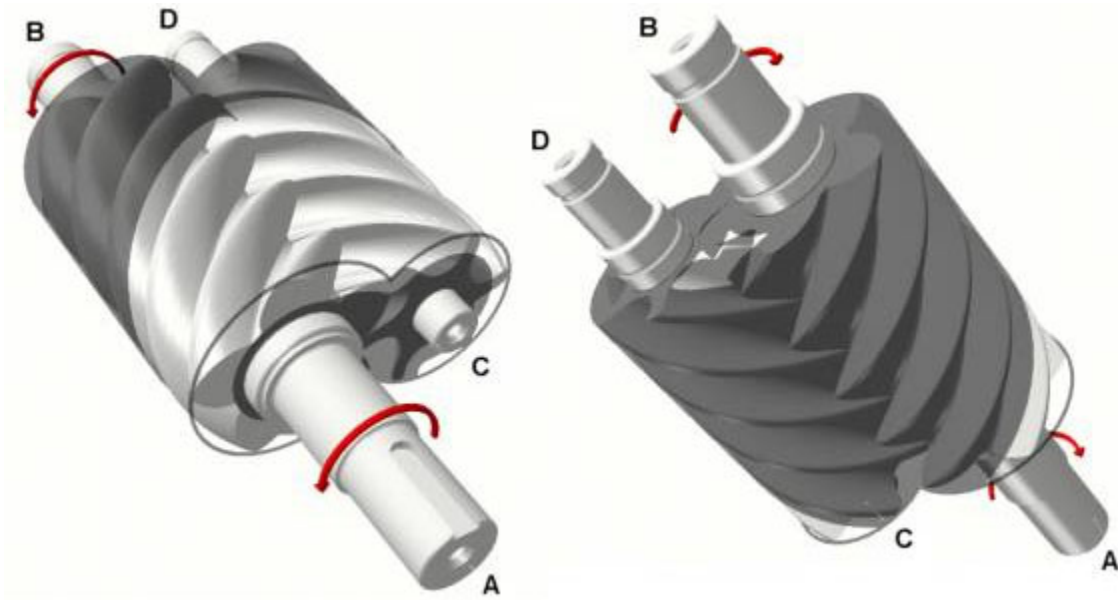

1a) View from Front and Top

1b) View from Bottom and Rear

Figure 1 Screw Compressor Main Components

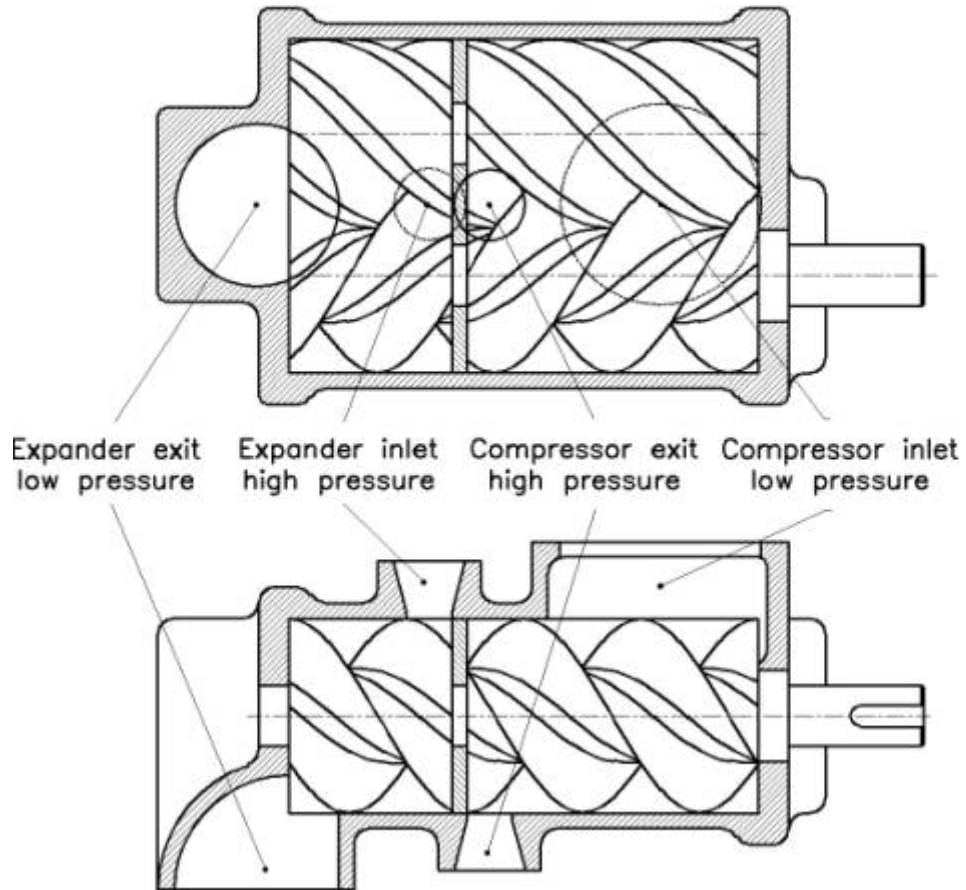

Figure 2 Schematic Diagram of the Screw Compressor Expander Combination

If combined, the expander power will reduce or even overwhelm the compressor power when the compressor will be completely driven by the expander. The combined expander-compressor power will in such a case depend upon the fluid flow and parameters through the both machines.

Fig 2 shows an arrangement of a screw machine that both compresses and expands the working fluid, which it is proposed to use in fuel cell applications. In this case, the compressor rotor shafts are extended to include expander rotors on them, so arranged that each set of rotors is contained in a separate chamber within a single casing, to form a combined compressor-expander machine. The layout by which the fluid enters and leaves this combined compressor-expander is critical because by this means, the load on the machine bearings is minimised.

As is shown, high pressure reaction products enter the expander port at the top of the casing, near the centre, and are expelled from the low pressure port at the bottom of the casing at one end, as a mixture of water and gas. The expansion process causes the temperature to drop. However, here the fall in pressure is used to recover power and causes the rotors to turn. Air enters the low pressure compressor port, at the top of the opposite end of the casing, is compressed within it and expelled from the high pressure discharge port at the bottom of the casing, near the centre, to be delivered to the fuel cell. Ideally, there is no internal transfer of fluid within the machine between the expansion and compression sections which each take place in separate chambers.

The main novelty of this arrangement is in the positioning of the ports. Because the high pressure ports are in the centre of the unit and arranged so that they are on opposite sides of the casing, the high pressure forces due to compression and expansion are opposed to each other and, more significantly, only displaced axially from each other by a relatively short distance. The radial forces on the bearings are thereby significantly reduced. In addition, since both ends of the rotors are at more or less equal pressure, the axial forces virtually balance out. Thus the bearing loads are substantially reduced and the effect of this will be to improve the overall efficiency of the machine by minimising the mechanical friction losses, which absorb approximately 10% of the input power in screw compressors.

3. Importance of the Compressor-Expander Efficiency

Using the data of *Hinsenkamp and Romba, 2002*, as a reference, a fuel cell with an overall efficiency of 50% was considered, for which a compressor, driven by an electric motor, without any power recovery from the expansion of the products, would absorb approximately 20% of the generated power output. Calculations were then performed to determine how much the inclusion of an expander in the system would improve its efficiency by reducing the electrical power input to the compressor.

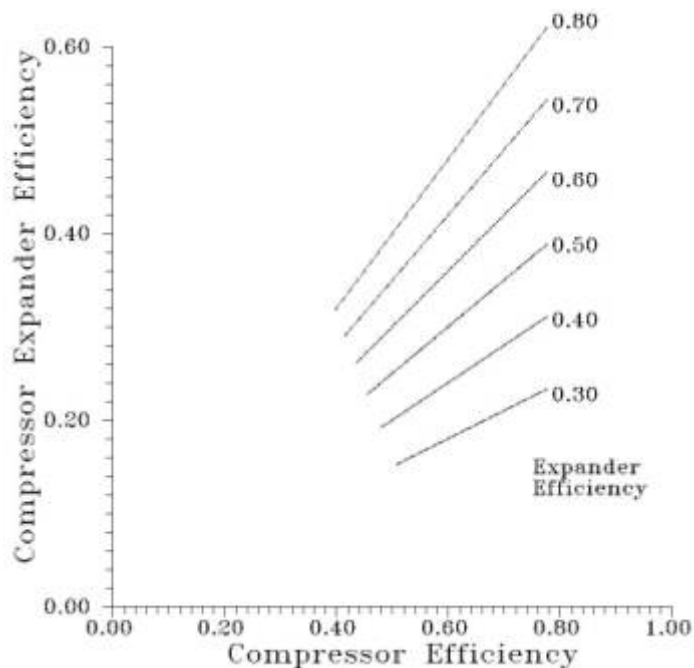

Figure 3 Efficiency of Screw Compressor-Expander

The results are shown in Figs 3 and 4. These cover a range of compressor and expander adiabatic efficiencies of between 0.3 and 0.8, which are effectively the maximum likely range for such machines. Two diagrams are presented in Figs 3 and 4, representing the effect of the compressor efficiency and the expander efficiency on the combined compressor expander efficiency and on the fuel cell efficiency. Clearly, the efficiency of the combined compressor-expander must be proportional to both the compressor and the expander efficiency but, as may be seen, even a very inefficient expander can improve the cell efficiency substantially.

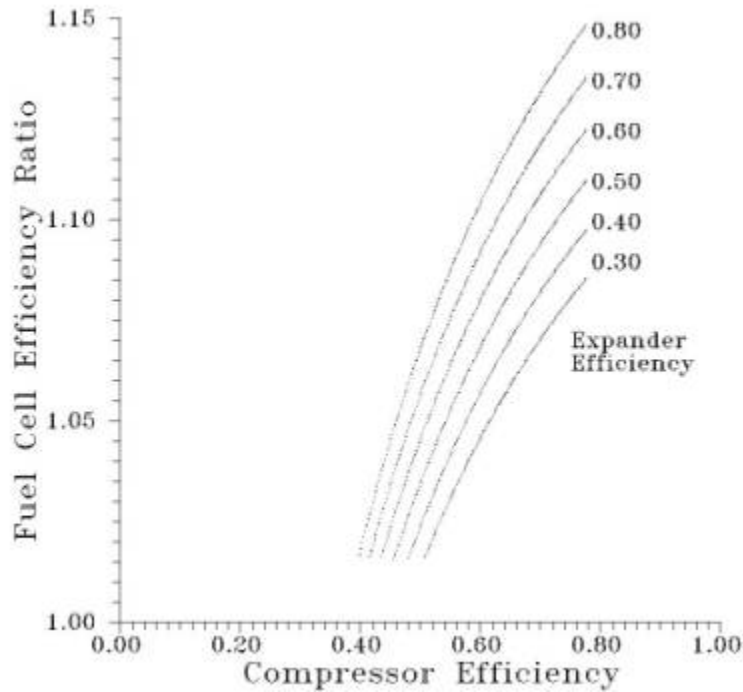

Figure 4 Increase of Fuel Cell efficiency by Use of an Expander

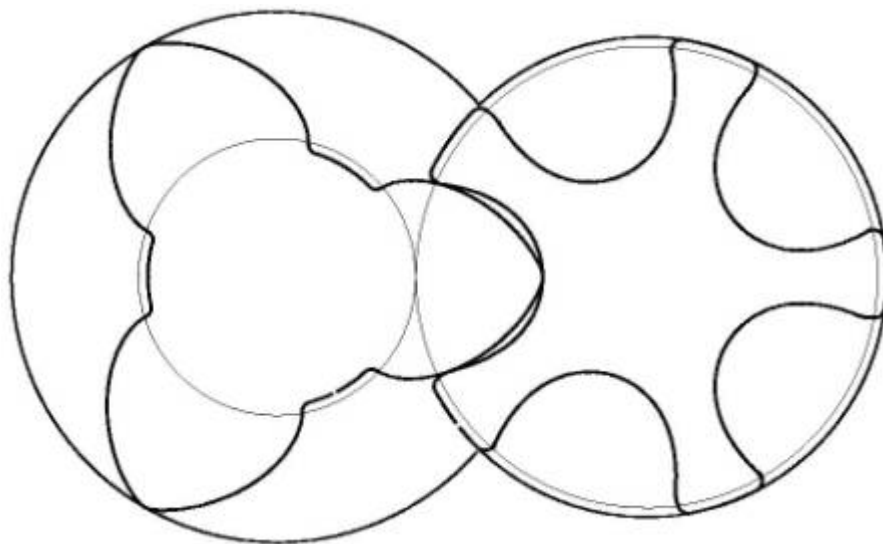

Figure 5 Compressor-Expander Rotors

4. Characteristics of the Combined Compressor Expander

A further feature of the proposed multifunctional rotors is the use of rotors, which form a full sealing line on both contacting surfaces so that the same profile may be used both for the expander and the compressor sections. In fact, since compression and expansion are carried out separately, the compressor and expander profiles could be different. However, this would make manufacture extremely difficult, due to the very small clearance space, which would be less than 10 mm, between the two rotor pairs. By using the same profile for both, the compressor and expander, the rotors can be milled or ground in a single cutting operation and then separated by machining a parting slot in them on completion of the lobe formation. Such rotors are presented in Fig. 5.

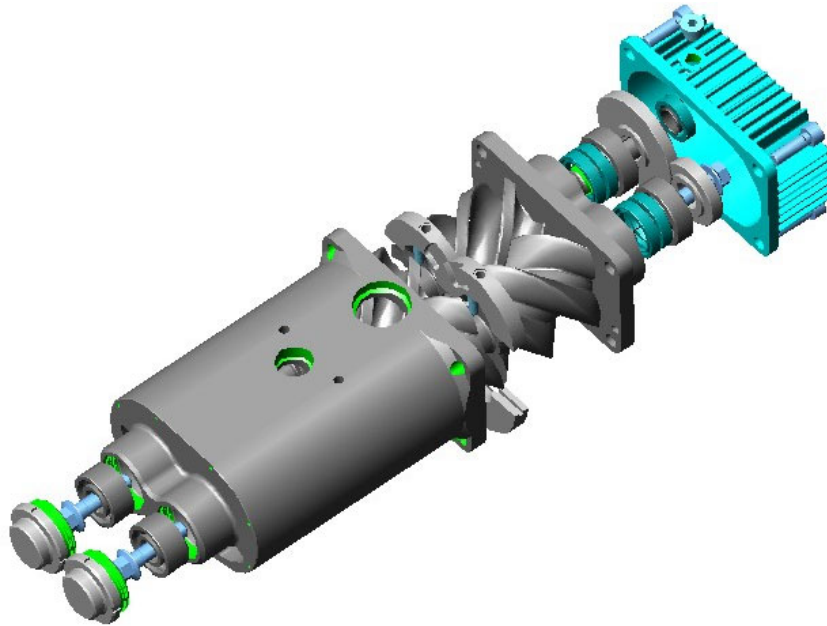

Figure 6 Expanded View of the Compressor-Expander



Figure 7 Compressor-Expander Prototype

A prototype of a similar machine was manufactured and experimentally investigated as a replacement of a throttle valve in a refrigeration plant. Such a machine is presented in Fig. 7. This was a direct contact machine with rotors lubricated by process fluid, while the fluid cell compressor-expander might be either dry or water injected. In both cases, rotor synchronization by oil lubricated gears, as well as oil lubricated bearings are recommended.

5. Conclusions

By proper location of the ports, it is possible to design a twin-screw machine in which both compression and expansion are performed in only one pair of rotors. Moreover, by locating the high pressure ports of the expander and the compressor on opposite sides of the casing, near its centre, the bearing loads can be reduced by balancing out the forces on the compression section of the rotors with those on the expansion section

By utilising this principle, together with a method of rotor profiling proposed by *Stosic, 1996*, it is possible to meet fuel cell requirements with a unit which is plainly simple in concept, cheap to manufacture and highly efficient. The authors believe that for the flow rate and pressure and temperature range of fuel cells, a combined screw compressor-expander on one pair of rotors is almost certainly the best ready available solution for the fuel cell application and a patent application has been filed on this principle. If water is injected into the compressor to reduce the temperature rise associated with the process, the pressure of the air delivered to the fuel cell can be increased from 3 to 10 bar. This opens new possibilities for the application of fuel cell technology in power generation applications.

It is shown in the paper that the compressor efficiency is a crucial element in the fuel cell overall performance, as well as this is any expansion of the fuel cell combustion products, which gives positive work. City University Compressor Centre, who are involved in research and development in screw compressor and expander technology, have developed a compressor-expander specifically for fuel cell applications, which embodies a number of novel and patented features, based on more than two decades R and D work on twin screw machines. Fully optimised design is based on advanced proprietary software. High compression and expansion efficiencies, due to patented “N” profile rotors. Improved overall efficiency due to reduced mechanical losses, resulting from a patented configuration, which balances the compressor and expander rotor loads. Low manufacturing cost due to the performance of both compression and expansion functions on a single pair of rotors, which are produced in one machining operation. The arrangement proposed in this paper for a fuel cell compressor-expander is such that both compression and expansion are performed simultaneously in only one pair of rotors. As a consequence the bearing loads are reduced by balancing out the forces on the compression section of the rotors with those on the expansion section. We believe that this arrangement, together with the proposed method of rotor manufacture in one go for both compressor and expander, will result in a unit that is practical, simple and cheap, as well as being very efficient. Moreover, if water is injected in the compression section, such a machine is capable of delivering air at pressures of up to 10 bars. This could make a substantial advance in the successful deployment of fuel cells for power generation.

6. Literature

- Fannar H, 2001*: Screw Compressor Internal Volume Control and Part Load Control System, Int. Conf Compressors and Their Systems, London, September 2001
- Grove W. R, 1839*: Phil Mag 14, 127
- Hinsenkamp G and Romba M, 2002*: Requirement for Air Management System in Automotive Fuel Cells, Scharubenmaschinen 2002, VDI Berichte 1715, Dortmund, September 2002
- Kauder K and Temming J, 2002*: Steady Operating Behaviour of a Screw Type Supercharger-Expander Module for an Automotive Fuel Cell System, Scharubenmaschinen 2002, VDI Berichte 1715, Dortmund, September 2002
- Smith I K and Stosic N, 1995*: The Expressor: An efficiency boost to vapour compression systems by power recovery from the throttling process, ASME Annual Conv, Heat Pump and Refrigeration Systems Design vol 34, p 173-181, 1995
- Stosic N, 1996*: Plural Screw Positive Displacement Machines, Patent EP 898655, US 6,296,461, WO9743550
- Stosic N, Smith I. K, and Kovacevic A, 2001*: Twin Screw Machines to replace Throttle Valve in Refrigeration Systems, Strojniški Vestnik, Journal of Mechanical Engineering, Ljubljana, Slovenia, 8 p 484, 2001
- Stosic N, Smith I. K. and Kovacevic A, 2002 a*: Plural-Screw Machines, Patent Application GB 0210018.8, May 2002
- Stosic N, Smith I. K, and Kovacevic A, 2002 b*: A Twin Screw Combined Compressor and Expander for CO₂ Refrigeration Systems, XVI International Compressor Engineering Conference at Purdue, July 2002